

A Proposal for IoT Based Automatic Solar Panel Monitoring System

Hemangi Mungad[#], Shradha Agrawal, Saurabh Verma, Kunal Ghorapade, Indu Dokare

Department of Computer Engineering

Vivekanand Education Society's Institute of Technology, Mumbai, India

[#]Corresponding Author, Email: 2015hemangi.mungad@ves.ac.in

Abstract— Internet of things (IoT) defines everyday physical objects being connected to the internet and identifying themselves to other devices on the internet to exchange data amongst them. This technology is useful in enhancing the performance, monitoring and maintaining various systems. The major challenge to the society is conservation of the energy. Though a lot of research work is going on in solar energy field, but still the solar based applications are not accepted easily by the people. This may be due to minimum knowledge of such applications. The proposed system aims to continuously supervise the monitoring and maintenance of the solar panels using IoT. The system should maximize its production and for that it being rotated as per sun's direction. The rotation of the panel will be in accordance with the real time position, intensity of the sun's radiation and climatic condition. In case the system is ineffectual to harness the required amount of energy for all the working home appliances at a definite time, the remaining energy will be acquired from other modes of electricity. The project highlights in providing analysis of the system data along with user friendly interface to the people. Timely notifications will be provided to the user regarding dust accumulation so as to restore the efficiency of the system and minimizing its effects in energy production.

Keywords— Internet of Things, Solar Panel, Sensors, Rotation

1. INTRODUCTION

Solar panel is a collection of photovoltaic cells, which generates electricity through the photovoltaic effect with the help of sunlight. These structures of the cells are like grid on solar panels surface. Generating power from photovoltaic plants is mobile as a result of variation in temperature, solar radiance and soiling. Thus remote monitoring is crucial. First the sunlight hits the panel which is

received by an inverter. The inverter then converts the electricity from DC to AC, which is used to power the residential locations or industries. The system will probably produce more energy during peak daylight hours compared to customers' usage, thus excess energy is stored in grids for later use. It is simple, clean and it's getting more efficient as well as affordable.

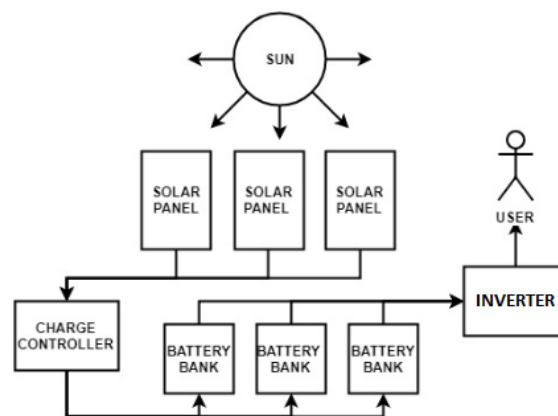

Fig.1: Solar Energy Conversion

As shown in Fig. 1, solar panel produces energy which will be provided to the charge controller. Charge controller is used to keep batteries from overcharging. The variable direct current output of a solar panel is converted into alternating 240V current by the inverter.

The remote examining will help to eliminate the risks associated with the wiring systems to measure data and supervising process simpler and cost-effective. IoT systems take an enormous leap towards monitoring systems by intelligent decision-making from the web. The current architecture of the remote

monitoring systems and its flexibility of implementation make it reliable for industrial issues. The remote monitoring systems have to fetch, analyze, transmit, manage and feedback the remote information by utilizing the most advanced science and technology in the field of communication technology and other areas.

Applications of solar energy:

Following are the few applications of the solar energy:

1. Homes: Residential gadgets can utilize electricity generated through solar power [1].
2. Commercial use: The panels can supply enough electricity to different offices of an organisation in a reliable way [1].
3. Swimming pools: Pool water can be kept hot by adding solar blanket to it [1].
4. Solar lights: These lights store sun's energy during daytime and then convert it into electricity at night [1].
5. Solar Cars: An electric vehicle can be charged with solar energy or sunlight [1].

Wi-Fi technology is used for remote monitoring and control of the photovoltaic system for household applications. Wi-Fi (IEEE 802.11g) operates at 2.4GHz and offer data rate as high as 54Mbps in contrast to ZigBee (250Kbps). However, this solution is preferred only for microgrid network architecture [2].

The proposed system focuses on supervising the monitoring and performance of the solar panels. The web portal aims to introduce a proposed method that helps the user to acquire the information regarding the condition and status about the solar panel efficiency and performance. The application also suggests rotating the solar panel according to the intensity of sun's radiation to produce high amount of energy with the help of real-time data. The dust sensors present is used to notify the user on excessive dust accumulation so that removing it will restore its previous efficiency.

2. COMPREHENSIVE EVALUATION

Generation of solar energy has enormous scope in India. The tropical location of the country benefits in generating solar energy. Almost, each and every part of India receives 4-7 kWh of solar radiation per sq meters which is equivalent to 2,300–3,200 sunlight hours per year. Promoting solar production technologies in rural areas will go as far away as majority of our population live in rural areas. Utilization of solar energy can reduce the use of firewood and dung cakes in rural locations thus reducing pollution. Some of the large projects proposed in India are:

- i) Thar Desert of India solar power projects is estimated to generate 700 to 2,100 GW
- ii) The Jawaharlal Nehru National Solar Mission (JNNSM) launched is targeting 20,000 MW of solar energy power by 2022
- iii) Gujarat's project to produce 20 GW of solar power by 2020 which was started in 2009.

Apart from above, about 66 MW is installed for various applications such as solar lanterns, water pumps and street lighting in the rural area. Thus, India has massive plan for solar energy generation that may not only fulfil the shortage of power generation but also contribute massively in green energy production to help reduce the climatic changes globally.

3. LITERATURE SURVEY

The major requirements about the integration of photovoltaic power generation systems into the affordable traditional generation systems will be monitoring photovoltaic generation systems and also adopting photovoltaic power generation systems to the present power system. A system with having these requirements was introduced for developed photovoltaic power generation system in the laboratory with Lab view by using its useful and effective tools. 1.2 KW grid connected photovoltaic system was used as a photovoltaic power generation system and NI USB-6221 data acquisition (DAQ)

card and developed electrical measurement circuits were used for monitoring the photovoltaic system. Parameters and parameter changes at current, voltage and generated power in photovoltaic system acquired from the system and these parameters were monitored in real time thanks to a Lab view DAQ card. Output voltage, output current and power generated from the photovoltaic system were also monitored with developing Lab view software [2].

One of the systems is developed on an online monitoring and control system for distributed. Renewable Energy Sources (RES) based on Android platform. This method basically uses the Bluetooth interface of the android tablet mobile phone as a communication link for data exchange with digital hardware of Power Conditioning Unit (PCU). The Low-Cost android tablet is suitable to replace the graphical LCD displays and Internet modem of RES Power Conditioning Unit (PCU) with enhanced graphical visualization and touch screen interface [3].

A professional O&M service package ensures that the solar photovoltaic system will assure to maintain high levels of technical and resultantly economic performance over its lifetime. Now, it is well acknowledged by all the stakeholders that high quality of O&M services aggravates the potential risks, improving the levelized cost of electricity (LCOE) and Power Purchase Agreement (PPA) prices and positively impacts upon the return on investment (ROI) [5].

Absorption of light in such material raises an electron to a higher energy state, and secondly, the movement of this higher energy electron from the solar cell into an external circuit. The electron then dissipates its energy in the external circuit and returns to the solar cell. A variety of materials and processes can potentially satisfy the requirements for photovoltaic energy conversion [1].

IoT built distant monitoring will help to raise energy efficiency of the system by making use of low power consuming advanced wireless modules thereby reducing the carbon footprint. A delivery of advance to remotely manage the Solar PV plants of various operations like remote shutdown; remote management is to be incorporated with this system later [2].

4. PROPOSED SYSTEM

Looking into the problems in the field of solar energy-based applications; the project aims to make the solar system more flexible and easier for users. The user is unknown about many of the parameters related to the solar panel. This project aims to provide users with detailed energy produced analysis. The proposed system works to monitor the state of a photovoltaic system through an IoT based network in order to control it remotely and used for maintenance of the system. The information from the sensors is transmitted via Wi-Fi module. A Wi-Fi module is laboured to transmit the data to the remote server and then be made visible to the user. Thus, the objective of the system is to improve efficiency of the solar panels and provide the system analysis to the user. The system block diagram shown in Fig. 2 consists of the hardware unit comprising of Arduino, sensors, battery and amplifiers. The other unit in this project is the web portal which will help the user to get the reports of energy production.

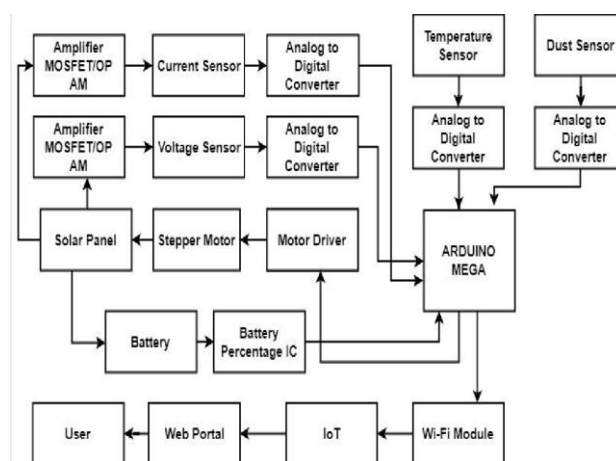

Fig. 2: System Block Diagram

The implementation steps involve:

4.1. Rotation of solar panel

The solar panel rotation system shown in Fig. 3 scans from one horizon to other to know the current position of sun which will determine the position generating maximum throughput. The position with the peak value of energy is chosen to charge the battery. In this way it can produce maximum energy from the solar panel by redirecting it continuously in sun direction in order to make it more efficient and smarter. In order to perform solar panel rotation, the system will be using real time data.

Arduino Mega is used for controlling Solar Panel Rotation with the help of Motor Driver and Stepper Motor. The Solar Panel will rotate with respect to sunlight with real fetch data. Current and Voltage sensors will calculate throughput at particular angels and will set the solar panel at that angel where there is maximum throughput.

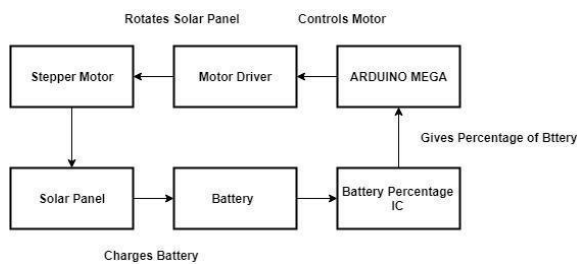

Fig. 3: Solar Panel Rotating

4.2. Notify the user

The system will show the present statistics of the solar panel, that is the production of current and voltage throughout the day and notify user timely. The system furthermore will provide user with predicated detailed report of the entire week’s production. Depending on data collected on the user energy requirement the system will predict if solar panel production is sufficient enough to generate the entire energy or it will need to switch to other modes.

4.3. Switching of energy source

The system will analyse the quantity of energy expected by all the home appliances to work as per its expectation. If the system

is unable to generate the required energy then it will switch to other mode of electricity.

4.4. Web Portal.

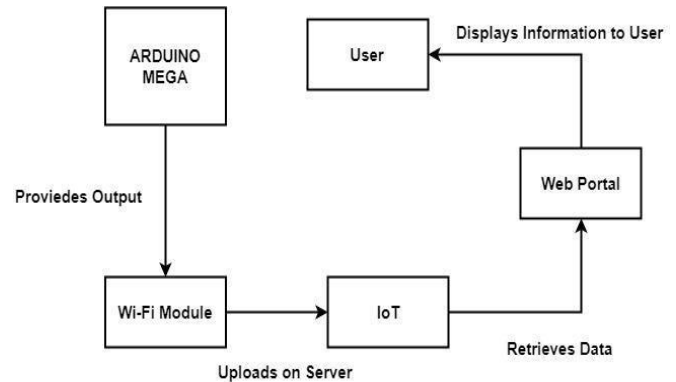

Fig. 4: Sensors

As shown in Fig. 4 Arduino Mega will be used to provide output to Wi-Fi module which will furthermore upload that information to IoT from which Web portal retrieves the data and provides it to user.

4.5. Sensors

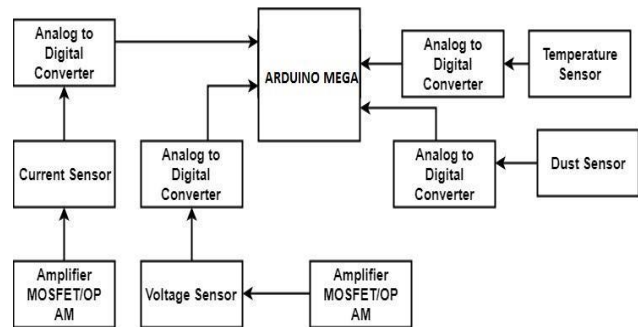

Fig. 5: Sensors

The system uses current and voltage sensors to measure current and voltage respectively produced by solar panels. Since, the value of current and voltage produced is very small amplifiers are used to amplify the current and voltage in the measuring range. Temperature and Dust sensors provide the real time data regarding heat and soiling effect respectively. Since the output generated by all sensors is in analog to digital converter is used.

5. EXPERIMENTAL SETUP

Fig. 6 shows the simulation of the system using Proteus software.

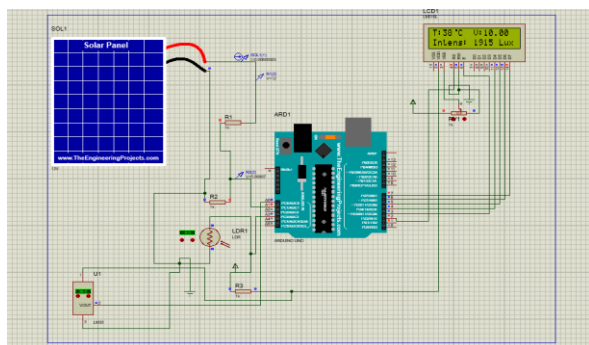

Fig. 6: Proteus Simulation of Proposed System

This setup displays how the virtual working module will look like. Voltage, LDR and Temperature sensors of panel act as input for Arduino Mega. LCD will display voltage, temperature and light intensity wherein Arduino acts as interface between LCD and input sensors. As the temperature will increase around the solar panel, arduino will update it on LCD display. The Light Dependent Resistor will calculate the light intensity around the solar panel and will display on LCD.

Voltage of the solar panel is very easy to measure when it is up to 5 volts. In case it being more than 5 volts then a voltage divider is required. Temperature measurement is done with the help of LM35 that gives 10 mV for every 1 degree Celsius.

The System will rotate wrt LDR and will stop where the solar panel is getting maximum light intensity.

6. CONCLUSION

This project provides a systematic approach of controlling and monitoring solar power panels from remote areas using Arduino Mega and web portal. GUI offer users interactive graphical interface for monitoring generation and consumption of power. Implementing this proposed prototype will be beneficial in terms of protection, operation and monitoring of solar systems.

7. FUTURE SCOPE

The external power required for functioning of the system can be provided by the energy generated from the solar panels itself. Also, with the help of machine learning algorithms and learning models it is possible to design a smart system which can analyse past data to predict and take decisions regarding the performance of the system to make it more reliable and efficient.

REFERENCES

- [1] Bagher, A.M., Vahid, M.M.A., Mohsen, M. "Types of Solar Cells and Application", American Journal of Optics and Photonics 2015; 3(5): 94-113
- [2] Adhya, S., Saha, D., Das, A., Jana, J., Saha, H. "An IoT Based Smart Solar Photovoltaic Remote Monitoring and Control unit", 2016 2nd International Conference on Control, Instrumentation, Energy & Communication (CIEC), 2016
- [3] Gkay, B., Mehmet, CEBEC. "Monitoring a grid connected photovoltaic power generation system with Lab view", Renewable Energy Research and Applications (ICRERA), vol. 562, no. 567, pp. 20-23, Oct 2013.
- [4] Jiju, K. et al., "Development of Android based on-line monitoring and control system for Renewable Energy Sources", Computer Communications and Control Technology (I4CT) 2014 International Conference, 2014.
- [5] Woyte, A., Richter, M., Moser, D., Mau, S., Reich, N., Jahn, U. "Monitoring of Photovoltaic Systems: Good Practices and Systematic Analysis", 28th European photovoltaic Solar.